

CAST IRON BALL VALVE PN 16



Size : DN 15 to DN 200
Ends : ISO PN10/16 Flanges
Min Temperature : -10°C
Max Temperature : + 200°C
Max Pressure : 16 Bars
Specifications : Full bore
Stainless steel ball
ISO 5211 mounting pad

Materials : Cast iron body

CAST IRON BALL VALVE PN 16
SPECIFICATIONS :

- Full bore
- Anti blow-out stem
- With O ring FKM on stem and PTFE washer
- ISO 5211 mounting pad
- ISO PN10/16 Flanges R.F. up to DN150 and ISO PN16 for DN200 (Threaded holes flanges for DN 125 and 150)
- Solid stainless steel ball up to DN 25, hollow ball from DN 32 to DN 200
- Black painting colour RAL 9004 5-15 microns thickness

USE :

- For all common fluids
- Min and max Temperature Ts : - 10°C to + 200°C
- Max Pressure PN : 16 bars
- **Do not use with steam**
- **Do not use with compressed air**

RANGE :

- Cast iron flanges R.F. with s.s. ball ISO PN10/16 from DN15 to DN150 and ISO PN16 for DN200 **Ref. 507** from DN 15 to DN 200

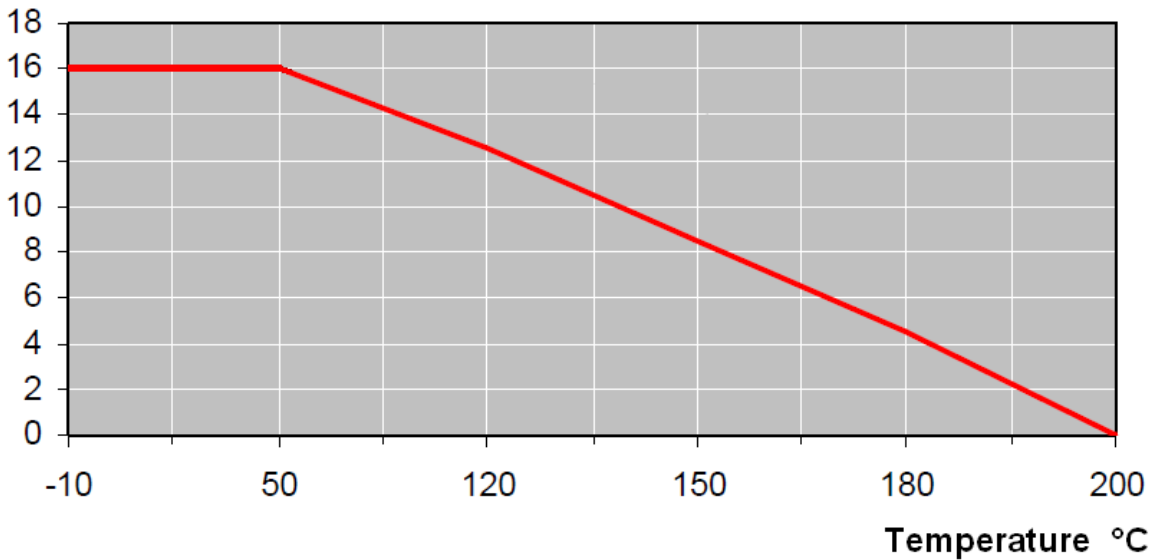
PRESSURE / TEMPERATURE GRAPH (STEAM EXCLUDED) :
P (bar)

FLOW COEFFICIENT Kv (in M3/H):

DN	15	20	25	32	40	50	65	80	100	125	150	200
Kv (M3 / H)	37.4	74.8	105	176	223	416	660	1200	1980	3600	5040	10890

CAST IRON BALL VALVE PN 16

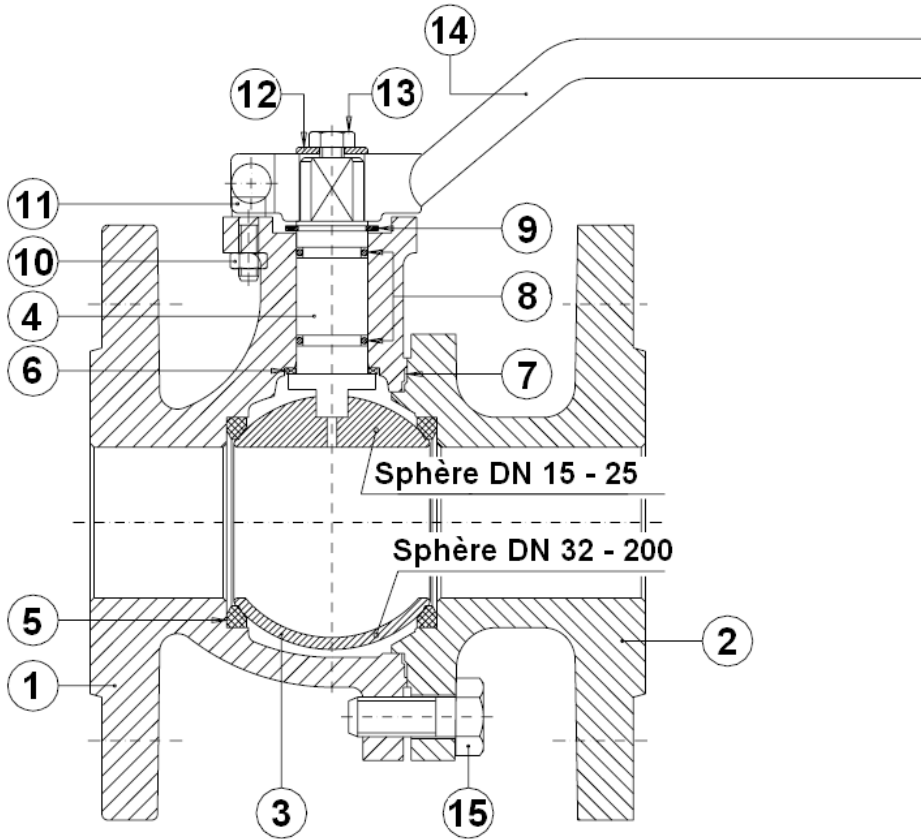
MATERIALS :



Item	Designation	Materials
1	Body	Cast iron EN GJL-250
2	Ends	Cast iron EN GJL-250
3	Ball DN 15 - 25	SS 303
3	Ball DN 32 - 200	SS 304
4	Stem	SS 304
5	Seat	PTFE
6	Washer	PTFE
7	Body gasket	PTFE
8	O ring	FKM
9	Stem washer	Steel DIN 471
10	Nut	Steel DIN 934 8
11	Screw	Steel DIN 912 8.8
12	Handle washer	Steel
13	Handle screw	Steel DIN 933 5.6
14	Handle	Steel
15	Body screw	DIN 933 5.6

CAST IRON BALL VALVE PN 16

VALVE SIZE (in mm) :

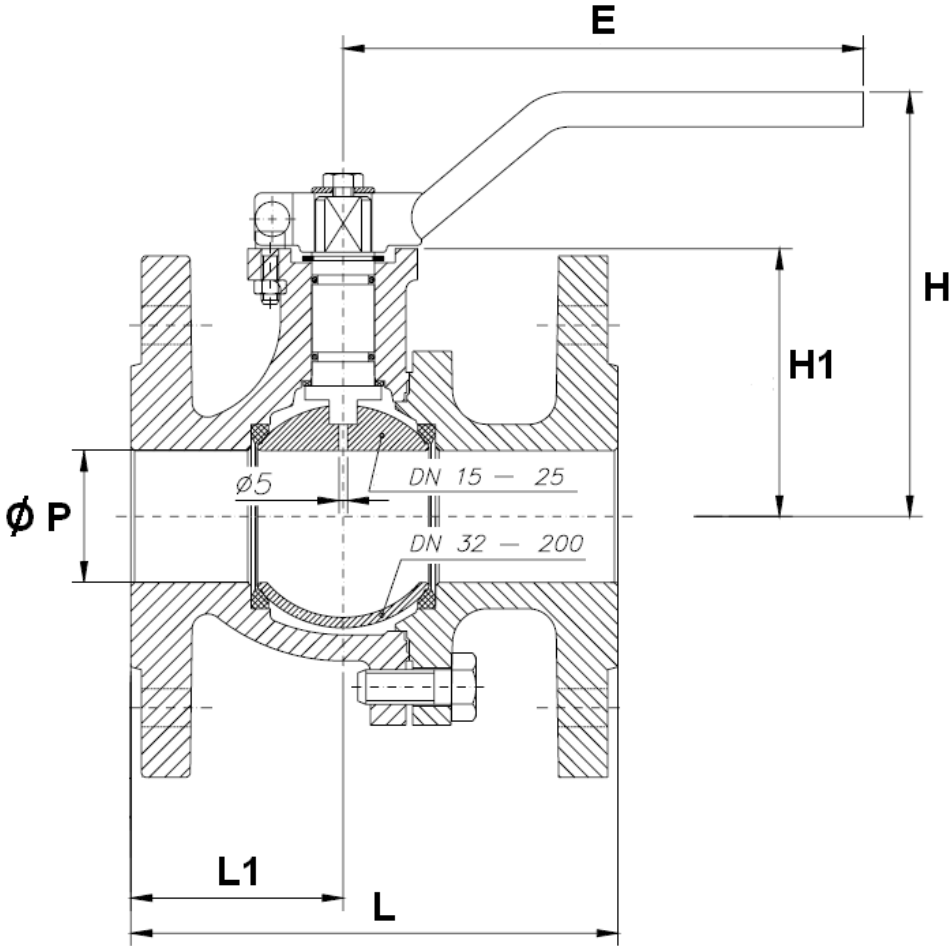

REF.	DN	15	20	25	32	40	50	65	80	100	125	150	200
507	Ø P	13	17	24	31	38	50	65	80	100	125	150	200
	L	115	120	125	130	140	150	170	180	190	200	210	400
	L1	49	55.5	51.5	53	61	62	81.5	79	94	120.5	155	190
	H	92	95.5	102.2	114.7	119	127	141	151.5	176.5	208	254.5	293.5
	H1	48.5	53	59.5	72	77	85	98	108.5	134	165	190	229
	E	170	170	170	170	302.5	302.5	335	335	350	350	500	500
	Weight (Kg)		2.12	2.72	3.62	5.32	6.9	9	11.68	14.68	20.23	33.73	49.77

CAST IRON BALL VALVE PN 16

STEM AND ISO MOUNTING PAD SIZE (in mm) :

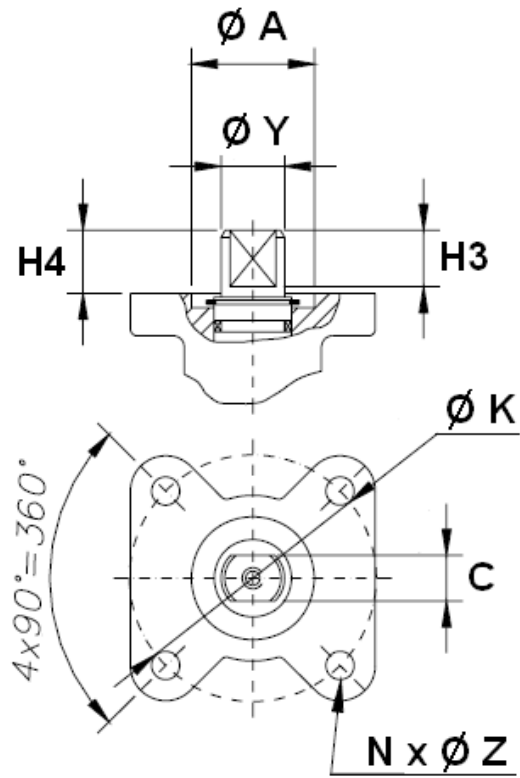

REF.	DN	15	20	25	32	40	50	65	80	100	125	150	200
507	Ø K	42	42	42	42	42	42	70	70	70	70	102	102
	ISO	F04	F04	F04	F04	F04	F04	F07	F07	F07	F07	F10	F10
	N x Ø Z	4 x 5	4 x 5	4 x 5	4 x 5	4 x 5	4 x 5	4 x 8	4 x 8	4 x 8	4 x 8	4 x 10	4 x 10
	C	7	7	7	7	12	12	13	13	16	16	20	20
	Ø Y	10	10	10	10	16	16	18	18	22	22	28	28
	H3	5.5	5	5	5.5	16	16	19	19	20	20	27	27
	H4	7.5	6	6.2	6.7	15	15	18	18	19	19.5	24.5	24.5
	Ø A	19	19	21	21	30	30	35	35	38	38	50	50

CAST IRON BALL VALVE PN 16

TORQUE VALUES (in Nm without safety coefficient) :

DN	15	20	25	32	40	50	65	80	100	125	150	200
Torque (Nm)	6	6	11	12	26	41	41	71	119	190	220	450

STANDARDS :

- Fabrication according to ISO 9001 :2000
- DIRECTIVE 97/23/CE : Risk Category I module A from DN65 to DN200
- Valve design according to DIN 3357
- Body design according to DIN 3840
- ISO 5211 mounting pad
- Length according to DIN 3202 F18 , EN 558-1 SERIE 27
- Flanges R.F according to EN 1092-2 PN10/16
- Marking according to EN 19
- Test according to EN 12266-1
- ATEX Group II Category 2 G/2Dc Zone 1 & 21 Zone 2 & 22 (optional marking)

ADVICE : Our opinion and our advice are not guaranteed and SFERACO shall not be liable for the consequences of damages.
The customer must check the right choice of the products with the real service conditions.

CAST IRON BALL VALVE PN 16**INSTALLATION INSTRUCTIONS****GENERAL GUIDELINES :**

- Ensure that the valves to be used are appropriate for the conditions of the installation (type of fluid, pressure and temperature).
- Be sure to have enough valves to be able to isolate the sections of piping as well as the appropriate equipment for maintenance and repair.
- Ensure that the valves to be installed are of correct strength to be able to support the capacity of their usage.
- **Installation of all circuits should ensure that their function can be automatically tested on a regular basis (at least two times a year).**

INSTALLATION INSTRUCTIONS :

- **Before installing the valves, clean and remove any objects from the pipes** (in particular bits of sealing and metal) which could obstruct and block the valves.
- **Ensure that both connecting pipes either side of the valve (upstream and downstream) are aligned (if they're not, the valves may not work correctly).**
- **Make sure that the two sections of the pipe (upstream and downstream) match, the valve unit will not absorb any gaps. Any distortions in the pipes may affect the tightness of the connection, the working of the valve and can even cause a rupture.** To be sure, place the kit in position to ensure the assembling will work.
- **If sections of piping do not have their final support in place, they should be temporarily fixed. This is to avoid unnecessary strain on the valve.**
- Tighten the bolts in cross.
- It's recommended to operate the valve (open and close) 1 to 2 times per year