

REF. 1123

WAFER BUTTERFLY VALVE PN10/16



ISO 9001

BUREAU VERITAS
Certification



CE

Size : DN 32/40 to DN 1000

Ends : Between flanges GN10/16, ASA150 up to DN600

Min Temperature : -10°C

Max Temperature : + 110°C (130°C temporarily)

Max Pressure : 16 Bars up to DN300

Specifications : Long neck for isolation

Stainless steel disc

Vulcanised elastic ring

Materials : Cast iron body

WAFER BUTTERFLY VALVE PN10/16

RANGE :

- With lever from DN32/40 to DN300
- Gear box (**Ref.1198**) possible from DN32/40 to DN1000

MATERIALS:

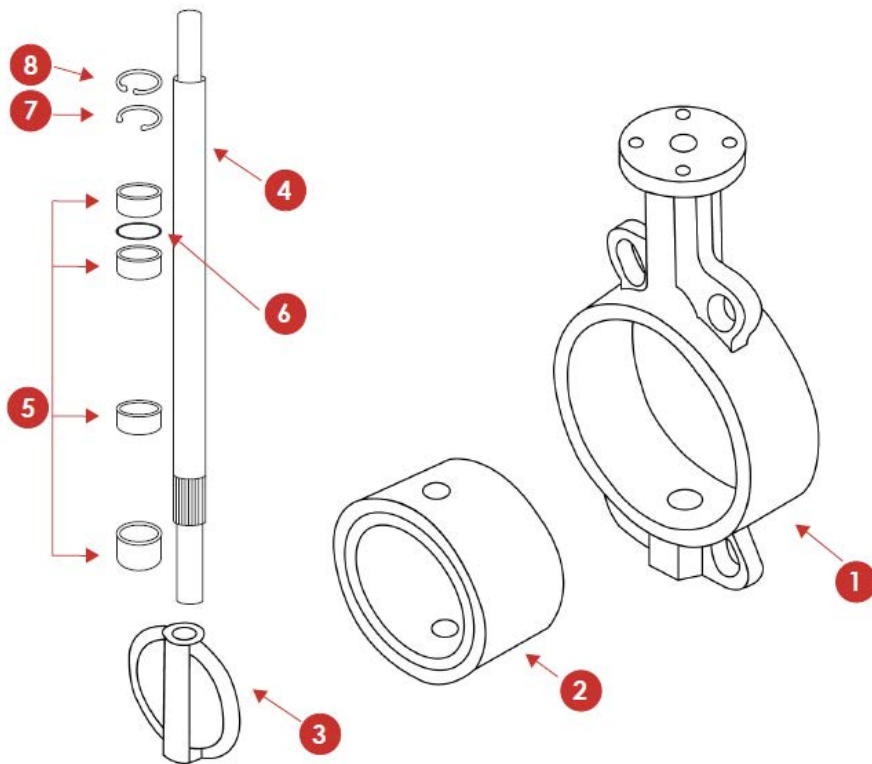

Item	Designation	Materials
1	Body	Cast iron EN GJL-250
2	Elastic ring	EPDM
3	Disc	SS 316
4	Stem	SS 416
5	Bearing	PTFE
6	O ring	NBR
7	Circlip	Steel
8	Circlip	Steel
	Lever	Aluminium

WAFER BUTTERFLY VALVE PN10/16

VALVE SIZE (in mm) :

- VALVES WITH LEVER DN 32/40 - 300 :

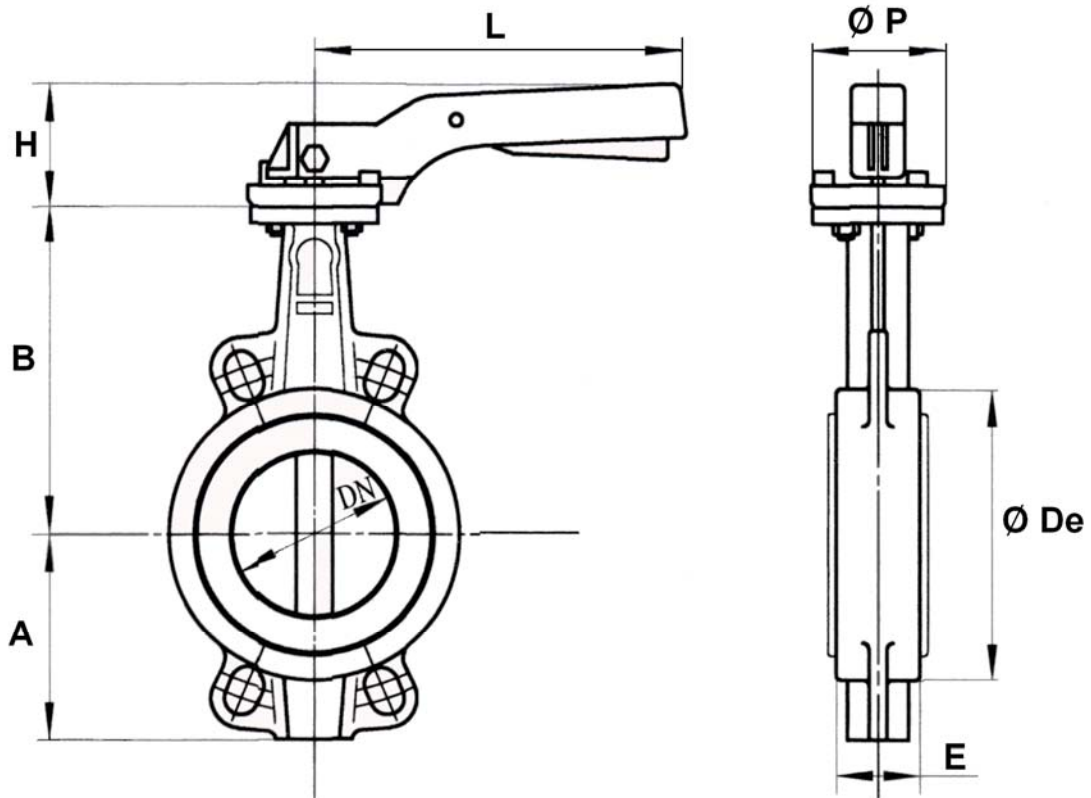

	DN	32/40	50	65	80	100	125	150	200	250	300
Ref. 1123	A	61	77	87,5	95	107	121,5	144	171	205	235
	B	130	136,5	142	158	180	192	215	242	280	310
	Ø De	82	95	109	127	152	180	207	260	315	370
	E	33	43	46	46	52	56	56	60	68	78
	H	74	74	74	74	74	79	79	37	37	37
	L	200	200	200	200	200	278	278	355	507	507
	Ø P	65	65	65	65	65	90	90	125	150	150
	Weight (Kg)	1.85	2.53	2.86	3.16	4.21	6.67	7.66	14.67	23.4	33.8

WAFER BUTTERFLY VALVE PN10/16

VALVE SIZE (in mm) :

- VALVES WITH GEAR BOX DN 350 - 1000 :

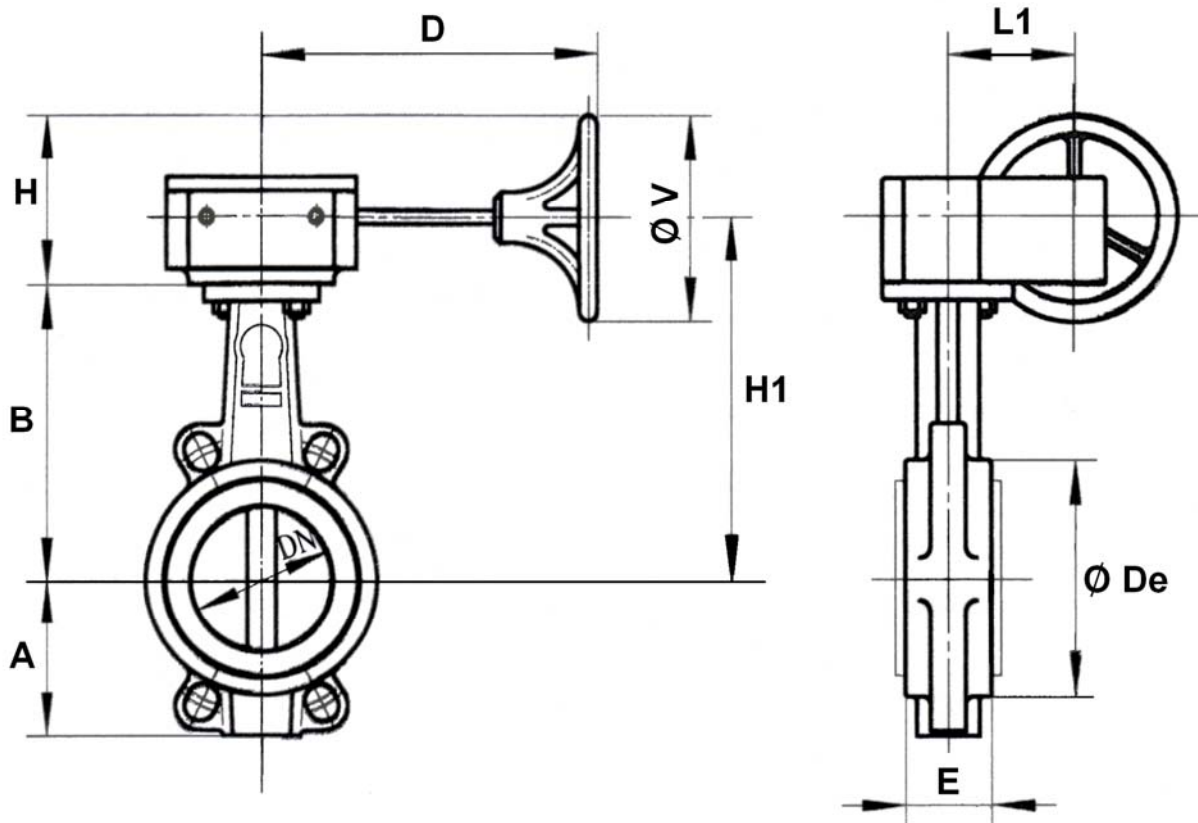

	DN	350	400	450	500	600	700	800	900	1000
Ref. 1123	A	258.5	303.3	323	350.5	444.5	520	591	656	721
	B	337	357	422	482	563	624	672	720	800
	D	223	270	270	339	339	357	357	410	410
	Ø De	418	470	525	575	693	800	906	1015	1134
	E	78	102	114	127	154	163	188	203	216
	H	189.5	207.9	257.5	221.5	221.5	381.5	381.5	475.5	475.5
	H1	376.5	415.2	437.9	497.8	688	705	742	854	932
	L1	78	120	120	120	120	243	243	278	278
	Ø V	300	300	400	300	300	435	435	435	435
	Weight (Kg)		54.5	89.85	107.4	155.8	231.1	398	456	852

WAFER BUTTERFLY VALVE PN10/16

GEAR BOX SIZE (in mm) :

- GEAR BOX DN 32/40 - 300 :

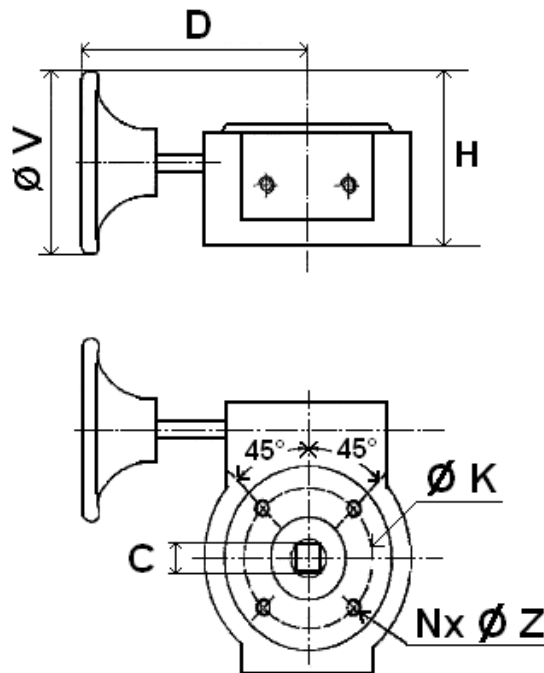

	DN	32/80	100	125/150	200	250	300
Ref.	C	9	11	14	17	22	27
	Ø K	50	50	70	102	125	125
1198	Nx ØZ	4 x 6	4 x 6	4 x 8	4 x 10	4 x 12	4 x 12
	D	156	156	156	241	223	223
	H	116	116	168	193	190	190
	Ø V	150	150	250	300	300	300
	Weight (kg)	3.51	4.22	3.53	6.99	7.42	9.6

WAFER BUTTERFLY VALVE PN10/16

ISO MOUNTING PAD SIZE (in mm) :

DN 32 – 600

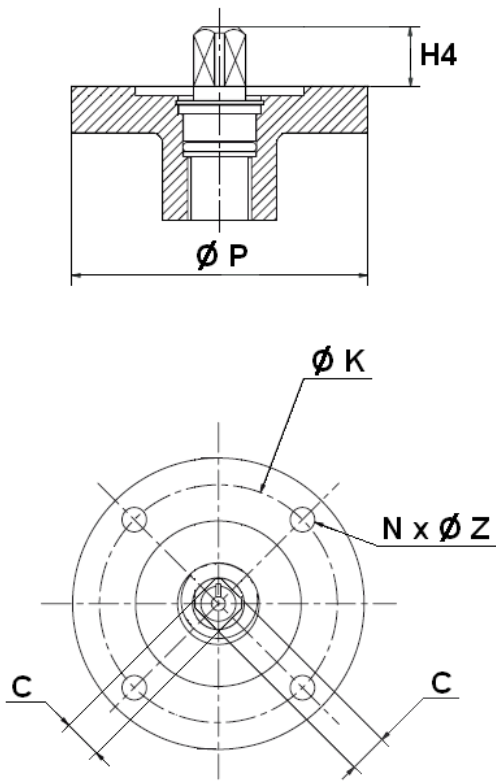

DN 700 - 1000

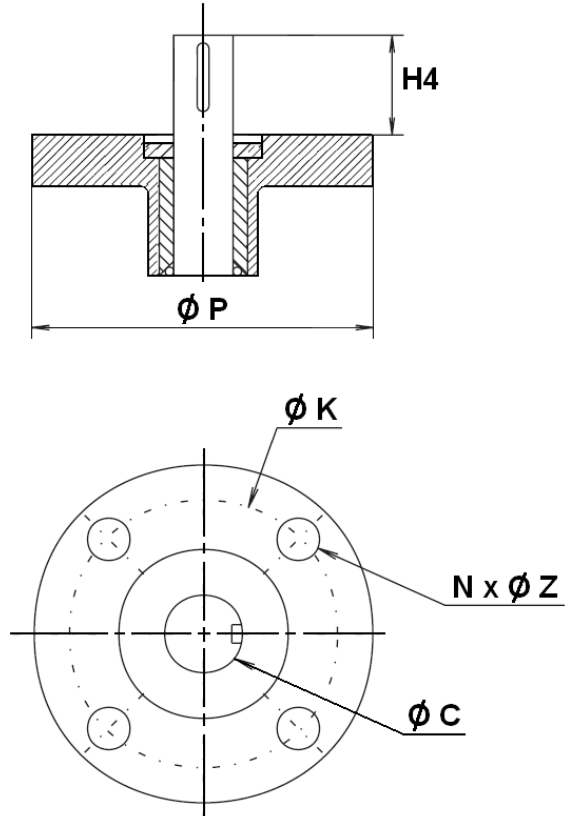

DN	32/40	50	65	80	100	125	150	200	250	300	350	400	450	500	600
C	9	9	9	9	11	14	14	17	22	27	27	27	30	30	40
Ø K	50	50	50	50	50	70	70	102	125	125	125	125	165	165	210
ISO	F05	F05	F05	F05	F05	F07	F07	F10	F12	F12	F12	F12	F16	F16	-
N x Ø Z	4 x 7	4 x 7	4 x 7	4 x 7	4 x 7	4 x 9	4 x 9	4 x 11	4 x 13	4 x 13	4 x 14	4 x 14	4 x 22	4 x 22	4 x 22
H4	32	32	32	32	32	42	42	36	38	38	45	50	50	65	70
Ø P	65	65	65	65	65	90	90	125	150	150	150	150	210	210	300

DN	700	800	900	1000
Ø C	63.35	63.35	75	85
Ø K	254	254	254	254
ISO	F25	F25	F25	F25
N x Ø Z	8 x 18	8 x 18	8 x 18	8 x 18
H4	80	80	118	142
Ø P	300	300	300	300

WAFER BUTTERFLY VALVE PN10/16

STANDARDS :

- Fabrication according to ISO 9001 :2000
- DIRECTIVE 97/23/CE : CE N° 0035
Risk Category I-III module H
- Tests according to API 598
- Length according to ISO 5752 NF 29305
- ISO 5211 mounting pad
- Between flanges according to EN 1092-1

ADVICE : Our opinion and our advice are not guaranteed and SFERACO shall not be liable for the consequences of damages. The customer must check the right choice of the products with the real service conditions.

INSTALLATION INSTRUCTIONS

GENERAL GUIDELINES :

- Ensure that the valves to be used are appropriate for the conditions of the installation (type of fluid, pressure and temperature).
- Be sure to have enough valves to be able to isolate the sections of piping as well as the appropriate equipment for maintenance and repair.
- Ensure that the valves to be installed are of correct strength to be able to support the capacity of their usage.
- **Installation of all circuits should ensure that their function can be automatically tested on a regular basis (at least two times a year).**

INSTALLATION INSTRUCTIONS :

- **Before installing the valves, clean and remove any objects from the pipes** (in particular bits of sealing and metal) which could obstruct and block the valves.
- **Ensure that both connecting pipes either side of the valve (upstream and downstream) are aligned (if they're not, the valves may not work correctly).**

WAFFER BUTTERFLY VALVE PN10/16

INSTALLATION INSTRUCTIONS (SUITE) :

- **Make sure that the two sections of the pipe (upstream and downstream) match, the valve unit will not absorb any gaps. Any distortions in the pipes may affect the tightness of the connection, the working of the valve and can even cause a rupture. To be sure, place the kit in position to ensure the assembling will work.**
- **If sections of piping do not have their final support in place, they should be temporarily fixed. This is to avoid unnecessary strain on the valve.**
- The valve must be inserted between flanges with disc half opened but the disc must not overpass the valve thickness. Position the bolts to keep centered the valve. Then open fully the valve and tighten the bolts. **See graph under.**

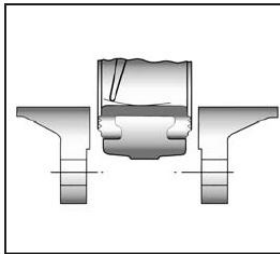

Half open valve introduction

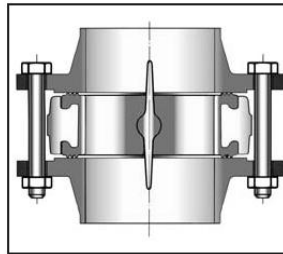

Complete opened disc valves when screw tightening

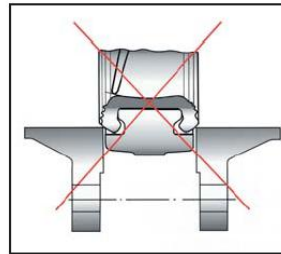

- Tighten the bolts in cross.
- The disc must move easily inside the pipe.
- Valves must be opened during cleaning operation.
- Tests must be done with a cleaned pipe.
- Tests must be done with opened valve. Test pressure must not be higher than the valve specification according to EN 12266-1.
- Then open slowly the valve.
- **Do not mount butterfly valves with stainless steel pressed collars and turning flanges.**
- **And not on flat face flanges without strias (example : painted cast iron fittings)**

MAINTENANCE :

- We recommend to operate fully the valve 1 to 2 times per year.
- During maintenance operation, ensure that the pipe isn't under pressure, that there's no fluid in the pipe and that the valve is isolated. If there's a fluid in the pipe, evacuate it. Ensure that there are no risks due to the temperature or the fluid (like acids). If the fluid is corrosive, inert the installation before maintenance operation.